

0371

为响应国家号召减少塑料制品对陆地及海洋环境的影响，我们研发的一款环保性能极佳的可回收PE底背

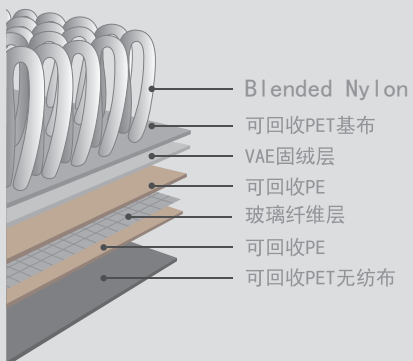

采用100%可回收材料底背



不含增塑剂
不含沥青



Blended Nylon
阻燃性能更优秀



Blended Nylon
易去污性能更卓越



环保鼓励类产品
方向，价格更实惠



比PVC底背轻约30%，
减轻建筑物承重负载



IMODULAR CARPET

TIANJIN. CHINA



037121+037122

0371

为响应国家号召减少塑料制品对陆地及海洋环境的影响，我们研发的一款环保性能极佳的可回收PE底背

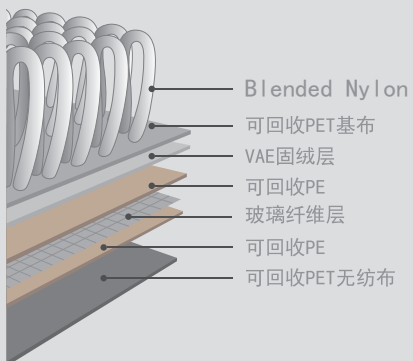

采用100%可回收材料底背



不含增塑剂
不含沥青



Blended Nylon
阻燃性能更优秀



Blended Nylon
易去污性能更卓越



环保鼓励类产品
方向，价格更实惠



比PVC底背轻约30%，
减轻建筑物承重负载

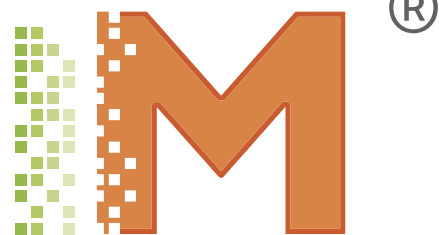

IMODULAR CARPET

TIANJIN. CHINA



037121

0371

为响应国家号召减少塑料制品对陆地及海洋环境的影响，我们研发的一款环保性能极佳的可回收PE底背

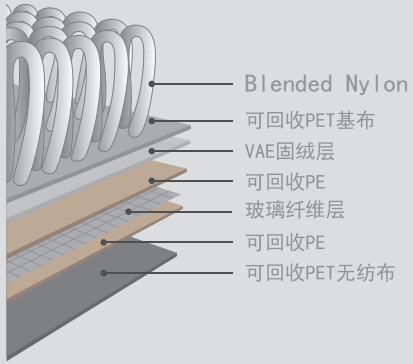

采用100%可回收材料底背



不含增塑剂
不含沥青



Blended Nylon
阻燃性能更优秀



Blended Nylon
易去污性能更卓越



环保鼓励类产品
方向，价格更实惠



比PVC底背轻约30%，
减轻建筑物承重负载



IMODULAR CARPET

TIANJIN. CHINA



037121+037131

0371

为响应国家号召减少塑料制品对陆地及海洋环境的影响，我们研发的一款环保性能极佳的可回收PE底背

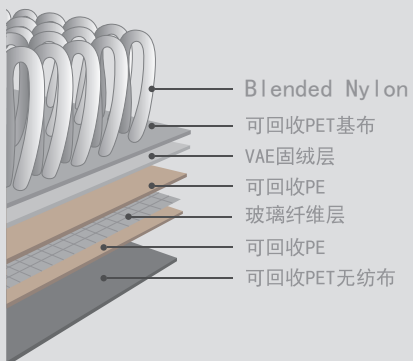

采用100%可回收材料底背



不含增塑剂
不含沥青



Blended Nylon
阻燃性能更优秀



Blended Nylon
易去污性能更卓越



环保鼓励类产品
方向，价格更实惠



比PVC底背轻约30%，
减轻建筑物承重负载

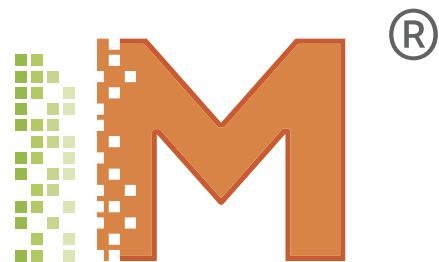

IMODULAR CARPET

TIANJIN. CHINA



037111

0371

为响应国家号召减少塑料制品对陆地及海洋环境的影响，我们研发的一款环保性能极佳的可回收PE底背

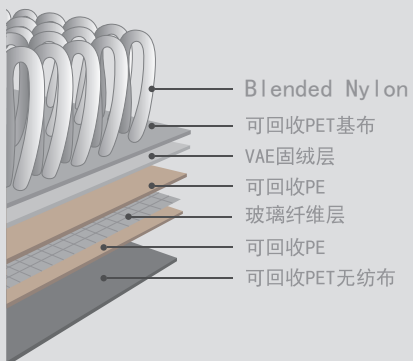

采用100%可回收材料底背



不含增塑剂
不含沥青



Blended Nylon
阻燃性能更优秀



Blended Nylon
易去污性能更卓越



环保鼓励类产品
方向，价格更实惠



比PVC底背轻约30%，
减轻建筑物承重负载

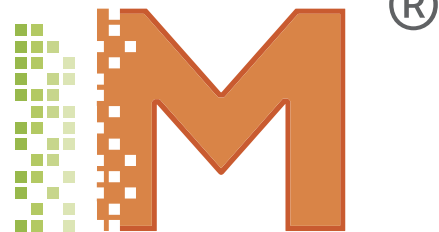

IMODULAR CARPET

TIANJIN. CHINA



037121+037122

0371

为响应国家号召减少塑料制品对陆地及海洋环境的影响，我们研发的一款环保性能极佳的可回收PE底背

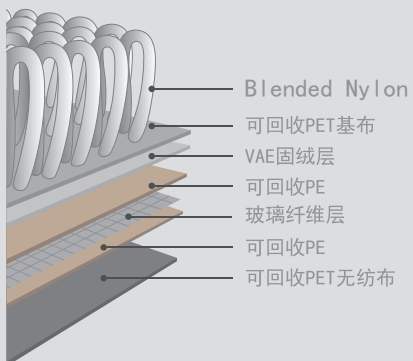

采用100%可回收材料底背



不含增塑剂
不含沥青



Blended Nylon
阻燃性能更优秀



Blended Nylon
易去污性能更卓越



环保鼓励类产品
方向，价格更实惠



比PVC底背轻约30%，
减轻建筑物承重负载

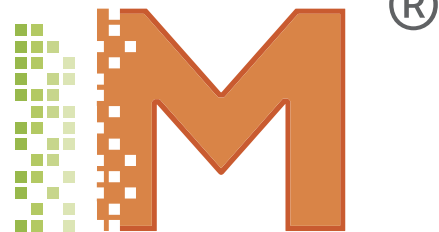

IMODULAR CARPET

TIANJIN. CHINA



037111+037121

0371

为响应国家号召减少塑料制品对陆地及海洋环境的影响，我们研发的一款环保性能极佳的可回收PE底背

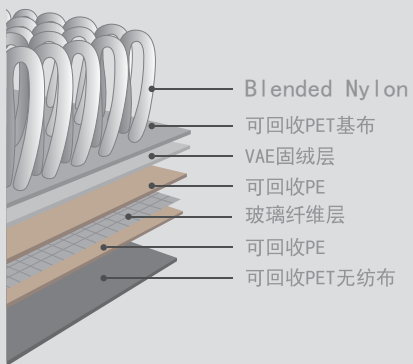

采用100%可回收材料底背



不含增塑剂
不含沥青



Blended Nylon
阻燃性能更优秀



Blended Nylon
易去污性能更卓越



环保鼓励类产品
方向，价格更实惠



比PVC底背轻约30%，
减轻建筑物承重负载



IMODULAR CARPET

TIANJIN. CHINA



037121

0371

为响应国家号召减少塑料制品对陆地及海洋环境的影响，我们研发的一款环保性能极佳的可回收PE底背

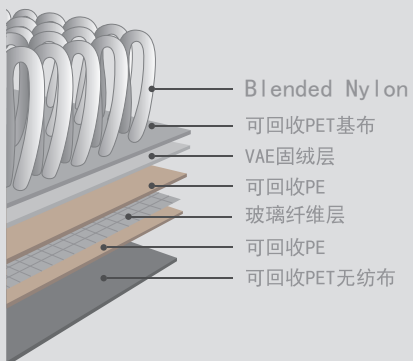

采用100%可回收材料底背



不含增塑剂
不含沥青



Blended Nylon
阻燃性能更优秀



Blended Nylon
易去污性能更卓越



环保鼓励类产品
方向，价格更实惠



比PVC底背轻约30%，
减轻建筑物承重负载

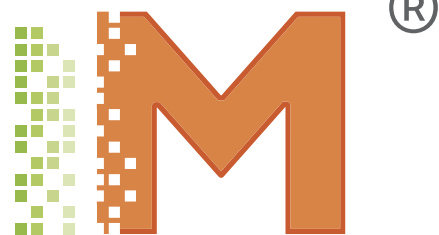

IMODULAR CARPET

TIANJIN. CHINA



037121+037122+037111

0371

为响应国家号召减少塑料制品对陆地及海洋环境的影响，我们研发的一款环保性能极佳的可回收PE底背

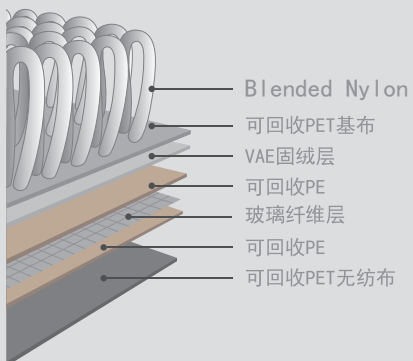

采用100%可回收材料底背



不含增塑剂
不含沥青



Blended Nylon
阻燃性能更优秀



Blended Nylon
易去污性能更卓越



环保鼓励类产品
方向，价格更实惠



比PVC底背轻约30%，
减轻建筑物承重负载

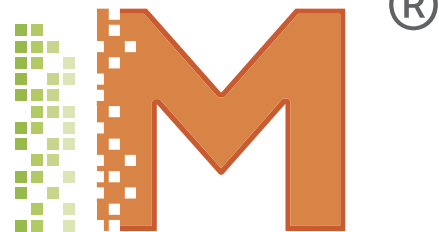

IMODULAR CARPET

TIANJIN. CHINA



037122

0371

为响应国家号召减少塑料制品对陆地及海洋环境的影响，我们研发的一款环保性能极佳的可回收PE底背

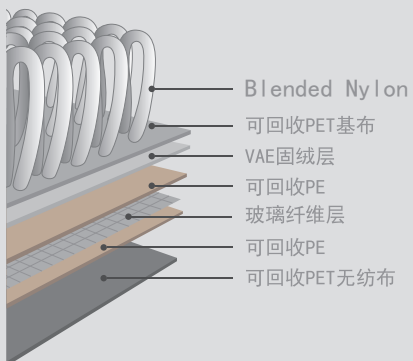

采用100%可回收材料底背



不含增塑剂
不含沥青



Blended Nylon
阻燃性能更优秀



Blended Nylon
易去污性能更卓越



环保鼓励类产品
方向，价格更实惠



比PVC底背轻约30%，
减轻建筑物承重负载

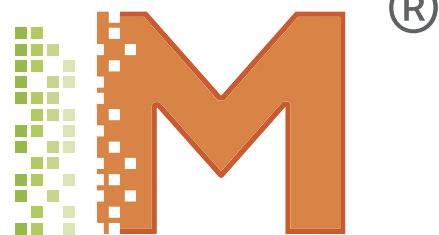

IMODULAR CARPET

TIANJIN. CHINA



037122+037131

0371

为响应国家号召减少塑料制品对陆地及海洋环境的影响，我们研发的一款环保性能极佳的可回收PE底背

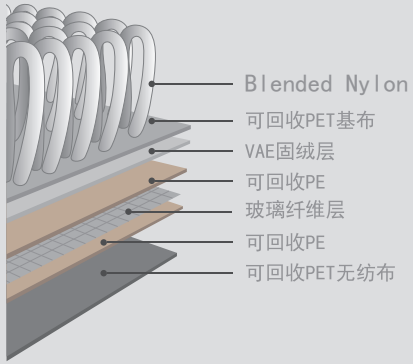

采用100%可回收材料底背



不含增塑剂
不含沥青



Blended Nylon
阻燃性能更优秀



Blended Nylon
易去污性能更卓越



环保鼓励类产品
方向，价格更实惠



比PVC底背轻约30%，
减轻建筑物承重负载



IMODULAR CARPET

TIANJIN. CHINA



037131

0371

为响应国家号召减少塑料制品对陆地及海洋环境的影响，我们研发的一款环保性能极佳的可回收PE底背

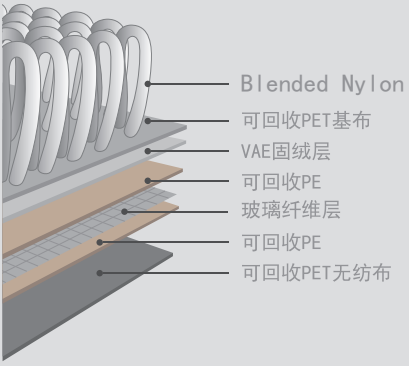

采用100%可回收材料底背



不含增塑剂
不含沥青



Blended Nylon
阻燃性能更优秀



Blended Nylon
易去污性能更卓越



环保鼓励类产品
方向，价格更实惠



比PVC底背轻约30%，
减轻建筑物承重负载



IMODULAR CARPET

TIANJIN. CHINA

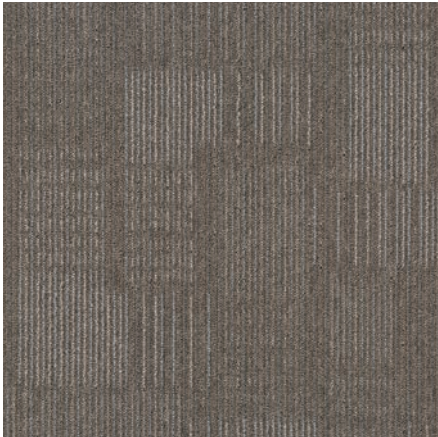

037111

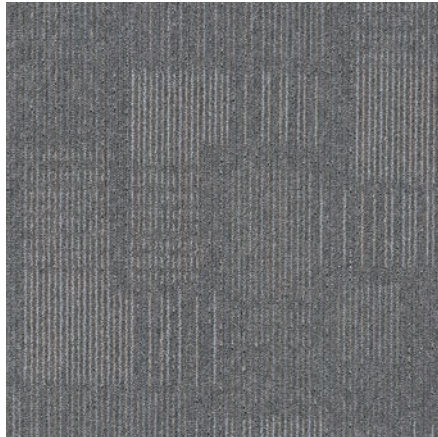

037121

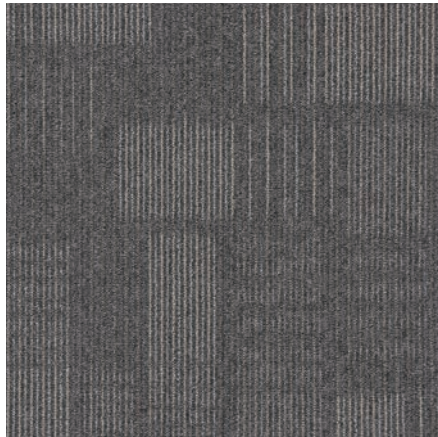

037122



037131

INSTALLATION INSTRUCTIONS:

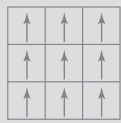

Monolithic

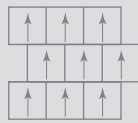

Horizontal Ashlar

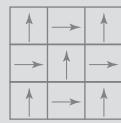

Quarter Turn

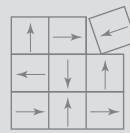

Random



PRODUCT INFORMATION

Style name/产品名称	0371
Construction/结构	Multi-level Loop
Fiber/纤维	Blended Nylon
Dye method/染色工艺	100% solution dyed
Backing/底背	可回收环保PE软底
Tufting Gauge/针密	47.00 rows per 10cm
Pile Weight/绒重	500g/m ²
Pile Height/绒高	3.5-5.5mm
Total Thickness/厚度	Approx 7mm
Tile Size/尺寸	500mmx500mm
Nbs Smoke 烟密度	(ASTM E 662)less than 450
Flooring Radiant Panel 临界热辐射通量	Class(Mean average CRF: 0.45 watts/cm ² orhigher) ASTM E-648
Electrostatic Propensity 静电倾向	3.0kV or lower AATCC 134
Colourfastness to Light 耐光色牢度	≥4 after 100 hours AATCC 16E

PRODUCT NOTES:

1. Product specifications are derived from averages resulting from normal manufacturing tolerances in yarn, fiber, temperature, humidity and colour. Product specifications may vary within normal industry and standardised testing tolerances.
2. These specifications reflect mean averages based upon tests of production runs of this carpet style by independent laboratories. A range of variances is implicit in the testing process. Furthermore, the standard test methods established to derive the specifications lack a degree of precision and repeatability; therefore, individual test results on the actual carpet purchased may differ from the specifications above.
3. Colours may vary slightly from dye lot to dye lot.
4. Backing or other materials may be changed without prior notice when shortages occur or when technological advancements become available which provit for improvement of the product's performance.
5. All products are 100% recyclable.